

COASTAL HYDRAULIC CRANES

MODEL NO. CJH 10-23

APPROX. WT.= 10,300 LBS.

MAX. OVERTURNING MOMENT = 565,060 FT-LBS.

MAX. VERTICAL REACTION = 30,300 LBS.

CAPACITY = 10,000 LBS. @ 23 FEET STATIC

7,000 LBS. @ 23 FEET DYNAMIC

SHIPPING INFORMATION:

BOOM STRUCTURE W/ TROLLEY:

27' X 3' X 5' CRATE WEIGHING 5,500 LBS.

PIPE MAST:

12' X 5' X 5' CRATE WEIGHING 4,800 LBS.

POWER PACK: 6' X 5' X 4' WEIGHING 1,600 LBS.

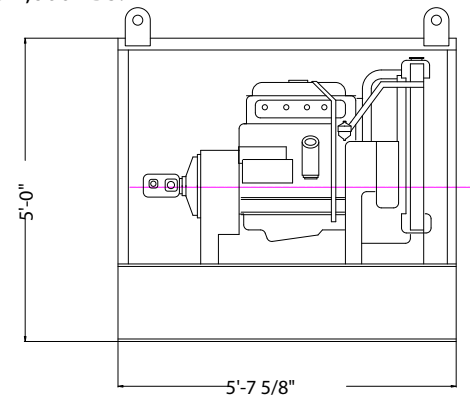
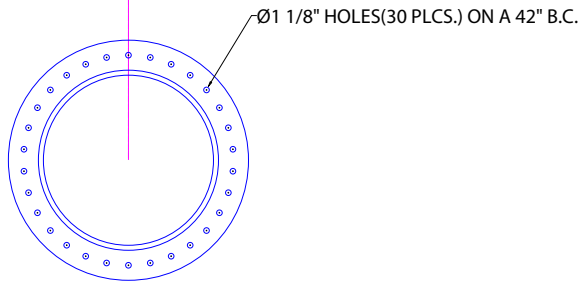

REMOTE HYDRAULIC POWER PACK
40 HP DIESEL ENGINE-TO-
25 GPM PUMP W/ ELECTRIC STARTER.